

- > **SEPARATOR PSS 1.1-300**
- > SEPARATOR PSS 1.2
- > SEPARATOR PSS 3.2
- > SEPARATOR PSS 3.3
- > SEPARATOR PSS 5.2



SEPARATOR

A BAUER GROUP COMPANY

EN



WASTE WATER TREATMENT

SEPARATOR PSS 1.1-300

ECONOMIC SLURRY TREATMENT



SEPARATOR PSS 1.1-300

Minimal total costs: energy efficient plus low initial investment

- Optimum cost-performance ratio
- Low operating costs
- Less space required
- Ideal for small farms with limited energy resources
- Wide range of Agricultural based applications
- Long life of wearing components

We want satisfied customers. Worldwide.

FAN Separator is a traditional European company with worldwide operations. We think, plan and produce according to strict European standards and ensure high quality in every detail. Our declared goal is the quality leadership in the areas of separation, slurry technology and also in sewage technology in the non-agricultural sector. For this, we work and produce sustainable and economic solutions. We live our tradition in the sense of modern value retention, and our mission is at the same time our top priority:
We want satisfied customers. Worldwide.

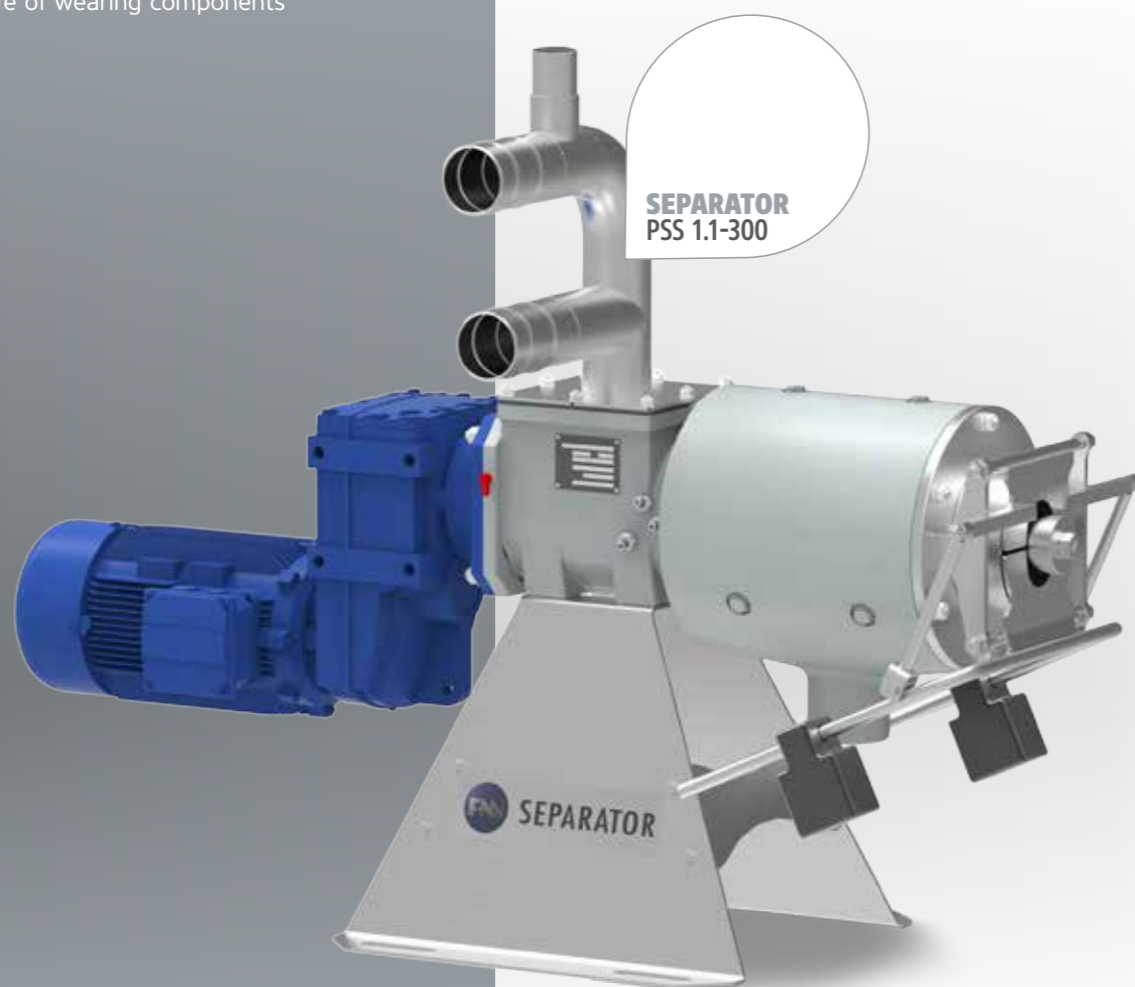
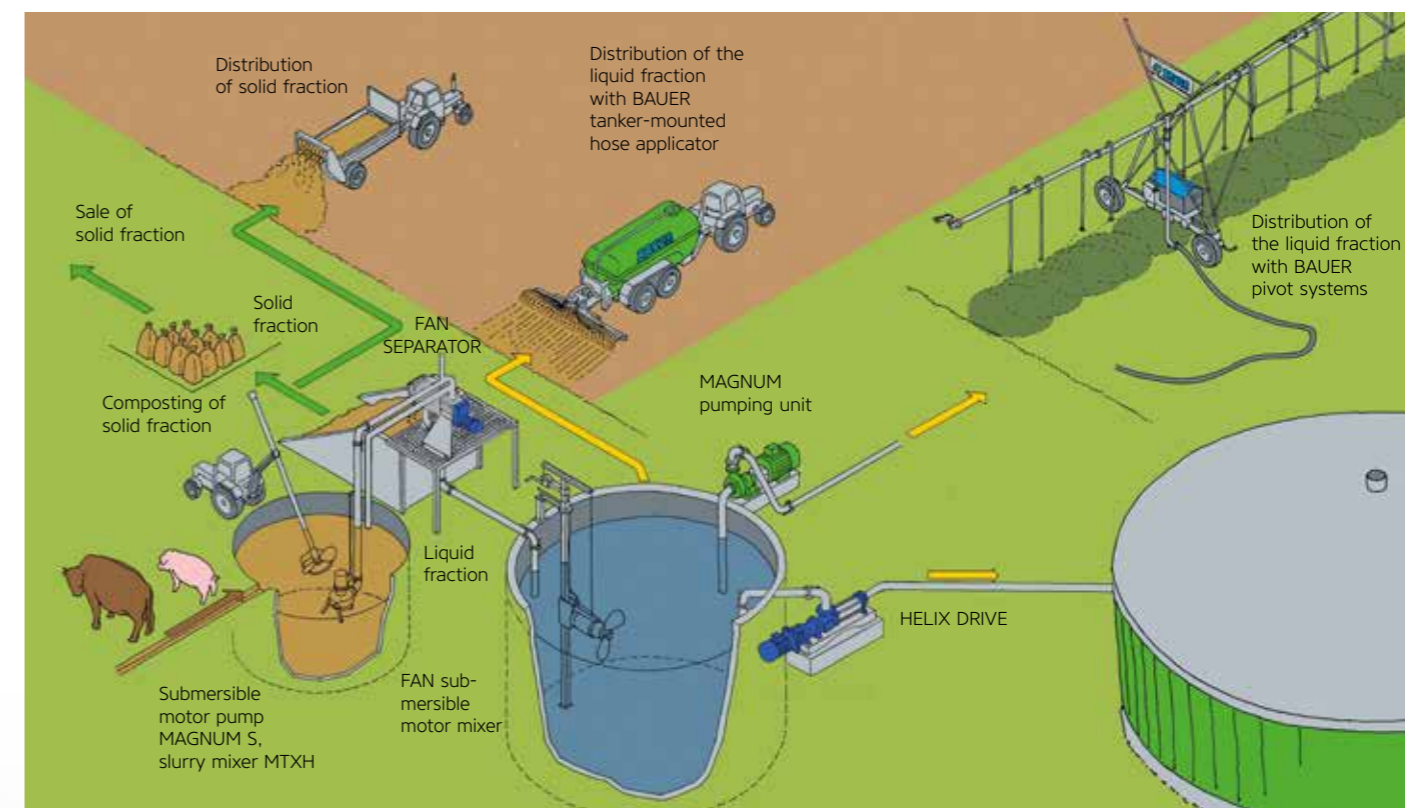

FAN technology leads in the separation of liquid from solid nutrients.

Product Description

The new design Press Screw Separator PSS 1.1-300 is a machine to separate solids and liquids with a rotating auger inside a full floating screen.

The medium is drained in the first part of the screen by gravitation. In the second step the medium is additionally extruded and exits the separator at the mouth piece.

In order to control dry matter content an output regulator is installed on the separator.

Site Suitability

The successor of the globally successful Solidry Separator is a lower-cost alternative to the existing FAN PSS 1.2 line.

Where no separator is currently installed and the separation process will cut cost or add value.

Features and Benefits

- 2.2 kW motor
- Throughput up to 16 m³/h
- Dry matter content up to 32%

Technical Data

Throughput, m ³ /h	up to 16
Dry matter content, %	32
Input power, kW	2.2
Screen sizes, mm	0.25 - 0.5 - 0.75 - 1.0

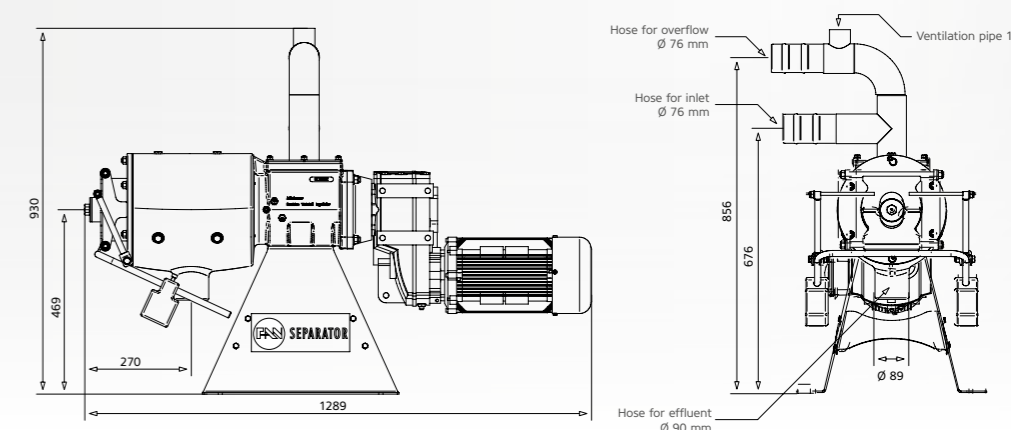



SEPARATOR

A BAUER GROUP COMPANY

PRODUCTS FROM OUR SLURRY PROGRAM



MSXH

Submersible motor mixer



SEPARATOR SPS

Sludge press for municipal and industrial waste water



SEPARATOR PSS

Press screw separator for solid-liquid separation

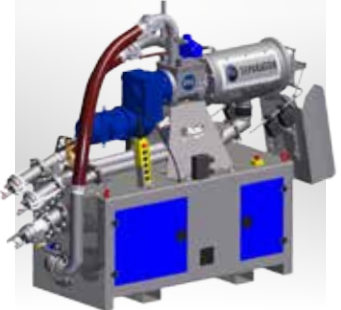

SEPARATOR PLUG & PLAY

System for portable slurry separation

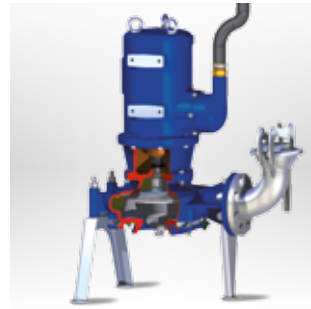

MAGNUM CSPH

Submersible motor pump gear unit design

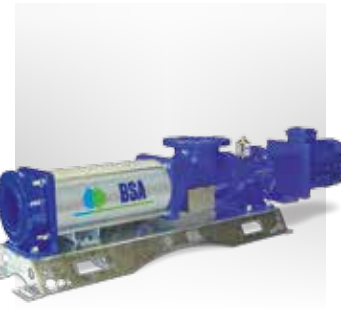

HELIX DRIVE

Eccentric screw pump unit design



BRU

Bedding Recovery Unit produces fresh bedding

Your dealer

FAN Separator GmbH

Bernecker Straße 5, 95509 Marktschorgast, Germany

T +49 9227 938-400

F +49 9227 938-444

M info@fan-separator.de

W www.fan-separator.de